





PAR56 REPLACEMENT PT90 / PT150 POOL LIGHTS MODEL OPERATING AND SAFETY INSTRUCTIONS

Congratulations, on your purchase of one of the most advanced LED leakproof sealed ceramic technology lights, in the world today. Your Next Generation PT90 / PT150 LED pool lights, will provide you with years of trouble free use and enjoyment. PT90 / PT150 fully sealed leak-proof technology has been proven internationally for many years. Since your new PT90 / PT150 is consumes less power, cool running, maintenance free you need never change a globe in your pools . Please take a few minutes to read and observe the following installation and safety information. PT90 / PT150 is 12V AC/DC unless specifically stated. Please visit our AqualDEA youtube to know more Installation information.

WARNING:

1. Our PT90 / PT150 are extremely bright, please **DO NOT** look directly at the light as it may damage your eyes.
2. All PT90 / PT150 **MUST** switch on under the water .
3. Accessories included as below:

-  Stainless steel mounting kits x 3
-  Stainless steel screw x 3
- Heat-Shrink Tube:
 -  Ø 3mm x 2
 -  Ø 9mm x 1
 -  Ø 15mm x 1



PT 90 Underwater LED pool lights x 1 / PT 150 underwater LED pool lights x1

RISK OF ELECTRICAL SHOCK OR ELECTROCUTION

This underwater lights fixture must be installed by a licensed pool's technician or certified electrician or a qualified pools serviceman in accordance with all applicable local codes and ordinances. Improper installation may create an electrical hazard which could result in death or serious injury to pool's users, installers or others due to electrical shock and may also cause damage to property. Always disconnect power to the pool lights at the circuit breaker before servicing the lights. Failure to do so could result in death or serious injury to serviceman, pool's user or others due to electrical shock. Common pool lights voltages are 12V AC/DC . **DO NOT** connect your new PT90 / PT150 the incorrect voltage or you may damage your lights and invalidate the warranty. All Pool lights **MUST** turn on under the water only.

INSTALLATION INSTRUCTIONS

A: Preparatory steps which must be completed by the electrician before lights is installed see Figure 1:

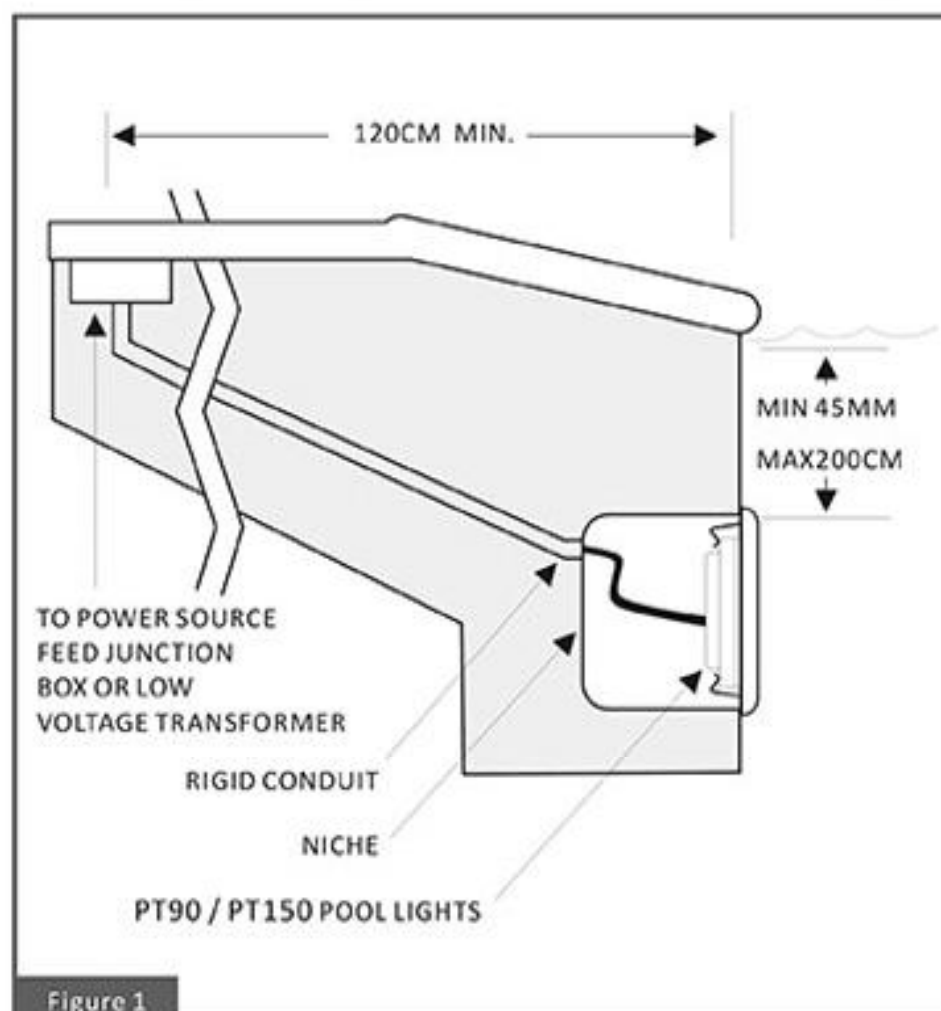

1. Ensure that the electrical system of the pool conforms to the requirements of all the local codes and ordinances. A licensed or certified electrician must install the electrical system to meet or exceed those requirements before the underwater lights is installed.
 - a) The junction box, or the low voltage transformer for 12 volt modes, **NEVER SUBMERGE THE TRANSFORMER** is located at least 120 cm from the edge of the pools, and is IP 64 splash rated see Figure 1
 - b) The lights fixture and all metal items within 240 cm of the pools must be properly electrically bonded.
 - c) The mounting bracket must be properly installed so that the edge of the face plate of the underwater light's LEDs are at least 45 cm below the surface of the water in the pools, see Figure 1.
2. Consult the local Government Building Department to be certain that the pool's electrical systems meet all applicable requirements.

Figure 1

PT model for the Niche mount rim

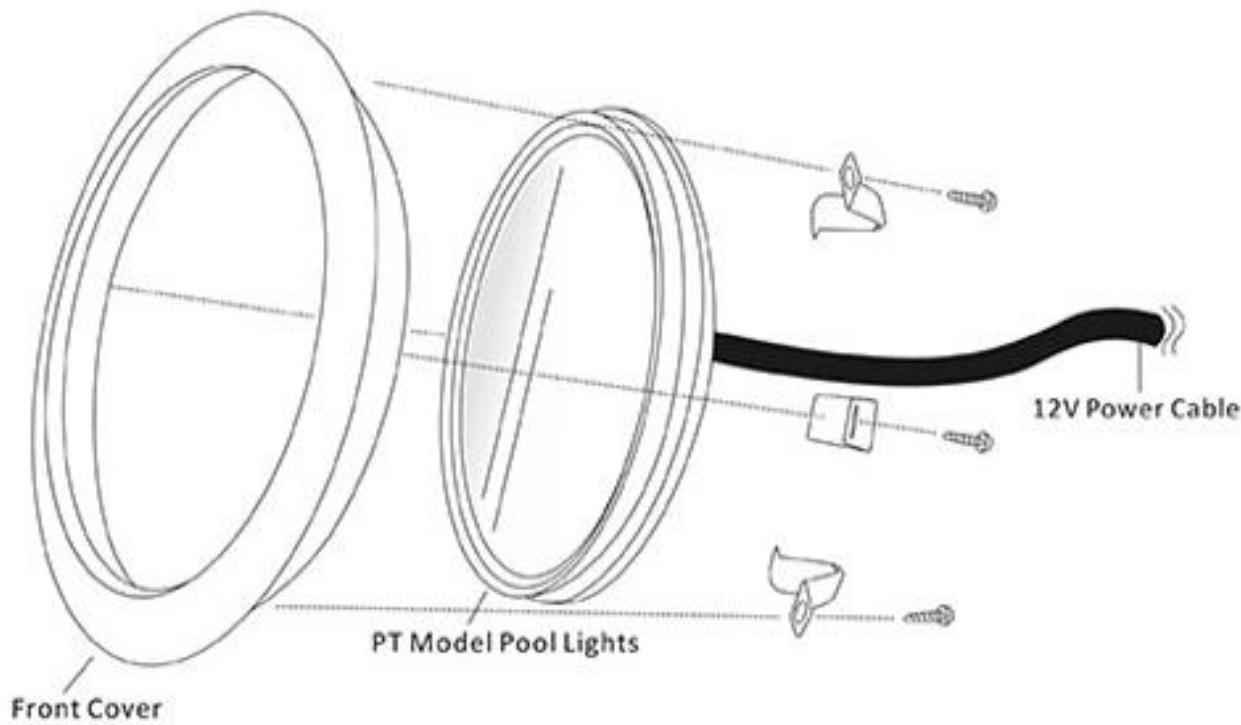

PT model for the Surface mount rim

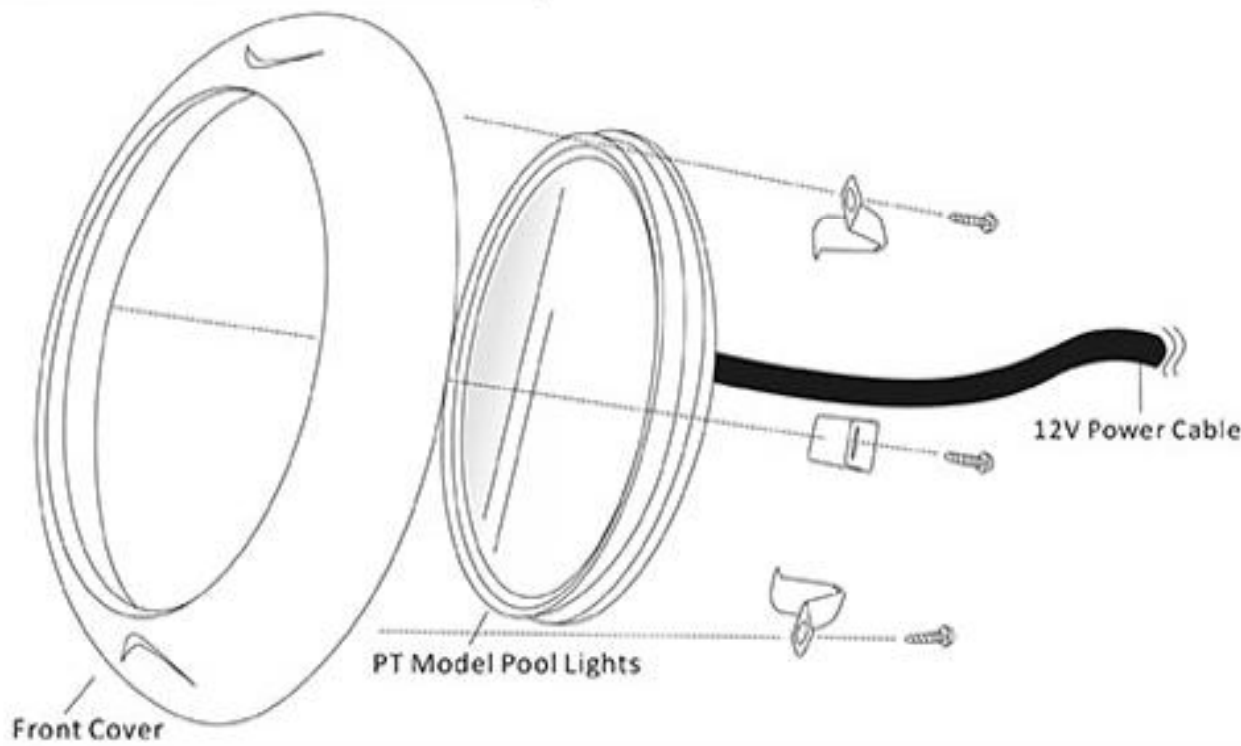

RGB COLOUR CHANGING CONTROLLER SYSTEM

PT90 / PT150 RGB lights should be installed on the same transformer and on the same switch. To achieve the synchronization when installing multiple lights on the same line. Make sure each light is installed correctly and on the same circuit. (Figure 4) Switch the lights for more than 10 seconds, the first colour changing program will started . Turn the lights off and wait for 1-2 seconds and turn them back on. Program will be changed . **If the pool lights are not at the same program. Please turn the lights off and wait 3-6second and turn the lights on . All pool lights program will back to program no 1 **

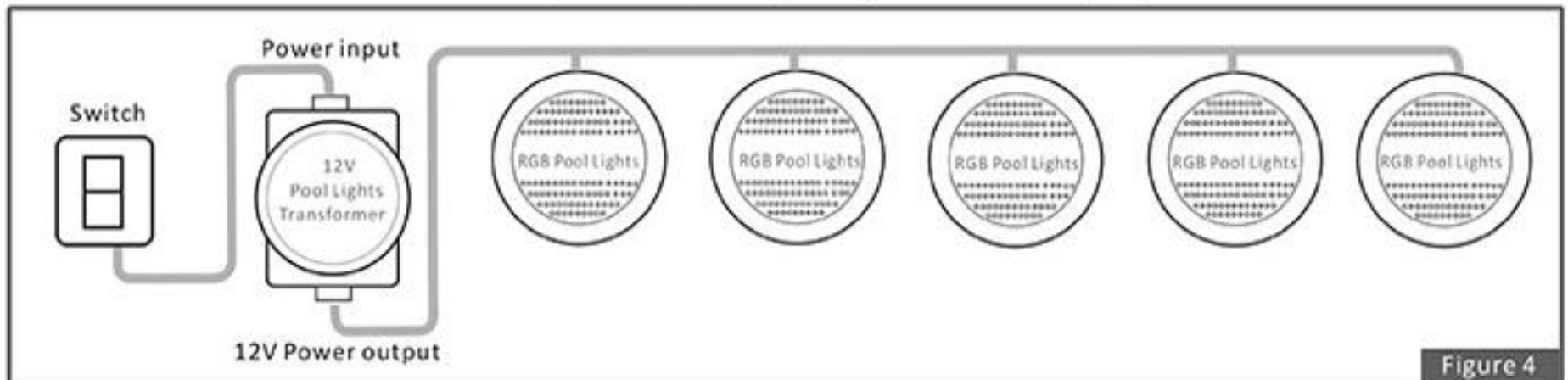

Figure 4

PT90 / PT150 RGB Programs

- | | | |
|---|-----------------------------------|-------------------------------------|
| 1. Deep Blue Sea :Slow animation for Blue | 5. Ocean Blue : One colour Blue | 8. Neutral white : One colour White |
| 2. Party :Fast animation for all colour | 6. Glass land : Blue and Green | 9. Pink Lady : Red/Blue |
| 3. Sun Set :Slow animation for Red | 7. Ocean Green : One colour Green | 10. Sunset : Red/Green/Blue |
| 4. Sky blue : Green and Blue | | 11. Orange Road : Red/ Green |