

### The AquaIDEA 20G Salt Chlorinator

Thank you for purchasing AquaIDEA's salt chlorinator for the treatment of swimming pool water.

The AquaIDEA's salt chlorinator is designed to operate for pool ranging up to 15,000-55000 liter of water.

3 grams to 6 grams of salt per liter of water is recommended for producing chlorine in keeping the pool water silky smooth and bacteria free. Reduces bacteria and virus presence to safe levels and produces pH friendly chlorine for your swimming pool.

Before using the equipment, please read the user manual carefully and keep it for future reference.

1. Electrolysis Cell
2. Power Pack

#### 1. Electrolysis Cell

The chlorinator electronics are carefully designed to be extremely robust and easily operated. The chlorinator comes with 4 buttons, Power-on/off, level up, level down and Super Shock button. Changing the level will cause the chlorinator system to generate different amount of chlorine by adjusting the power delivered to the electrolysis-cell. Special plating is being used on the electrolysis cell to minimize the residual left during the electrolysis process. High-strength epoxy material is used to seal the electrolysis cell for prolonged maintenance-free operation.

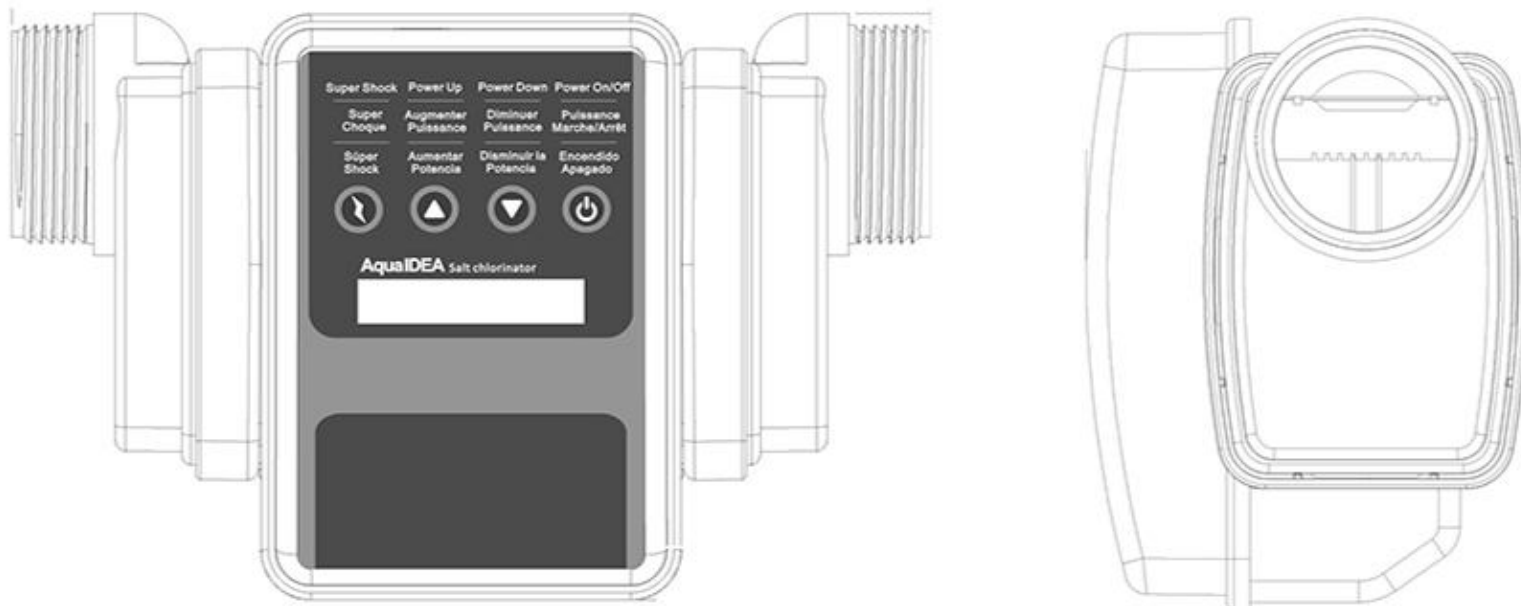

Specifications :Recommended salinity:3 to 6 grams per liter of water (3000 to 6000 ppm)

Electrodes: Automatic self-cleaning electrodes, 7amps with 3 plates

Production rate: Max 20g / hour Minimum flow rate:2m<sup>3</sup> / hour

AC power:220V AC / 85W / 18V / Fuse: 1 Amps

Working Temperature: less than 50°C

#### How does the chlorinator system installed in swimming pools?

The electrolysis cell will be mounted after the filter line. The electrolysis cell is in operation when the filter pump is turned on. The electrolysis process converts salty water into sodium hypochlorite in order to minimize the bacteria level. The optimal salt concentration is 3 to 6 g/liter. Such concentration is roughly double the average salt concentration in freshwater system.

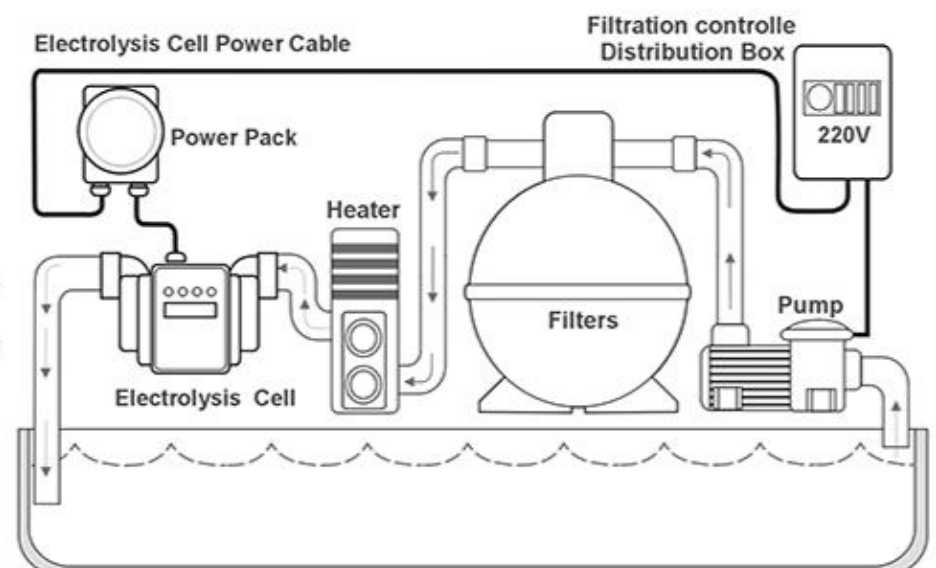

### The POWER PACK Installation:

The Chlorinator Power Pack should be mounted vertically on a solid and rigid surface. Good installation practice, dry and open area for ventilation will maximize the life of the Chlorinator Controller for prolonged usage.

Outdoor installation of the Power Pack is prohibited.

It is preferably to be secured by 4 screw and keep a distance from the Electrolysis Cell since water splashes will damage the Chlorinator Power Pack electronic.

The Power Pack AC power cable must be connected to either the pump timer or to the pump motor AC power line.

The Power Pack functions may only be set when the filtration system is running.

**Caution:** This MUST be undertaken by a registered electrician.

### The ELECTROLYSIS CELL Installation Instruction

#### RECOMMENDED

Connector area MUST be faced upward Mount electrolysis cell horizontally

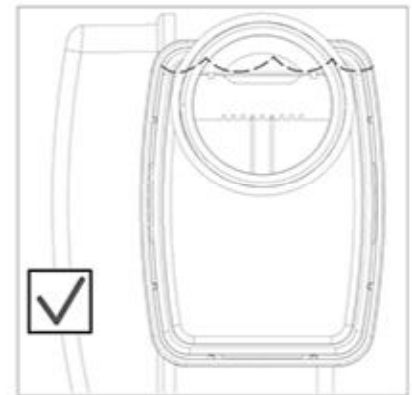
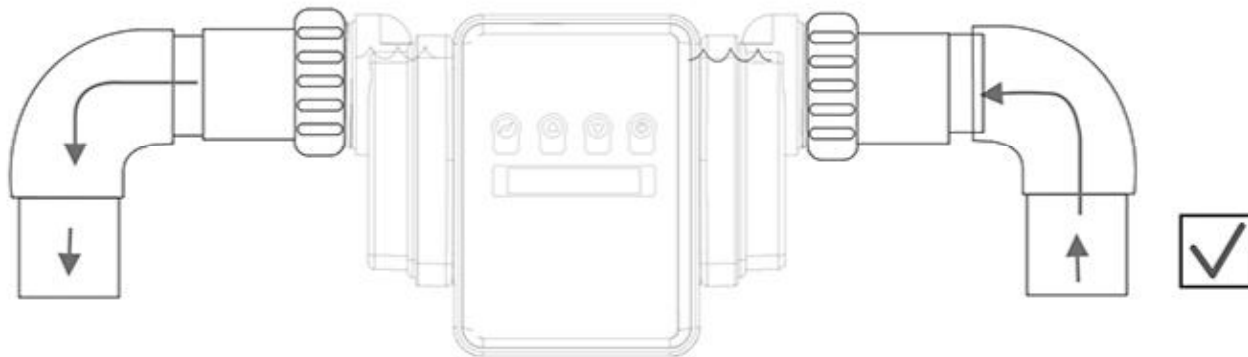

The Electrolysis Cell must be installed indoor. It should be placed after the pool filter horizontally so the system can detect the water level. If the system detected the water level less than 90% in the Cell. The system will decrease the power to self checking mode and warning alarm on. If the water under lower level over 30min. System will shut down automatically in order to protect the electrolysis cell.

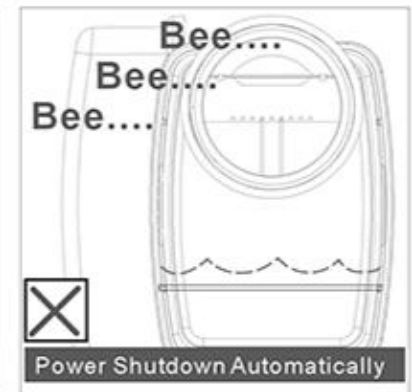

#### NOT ACCEPTABLE

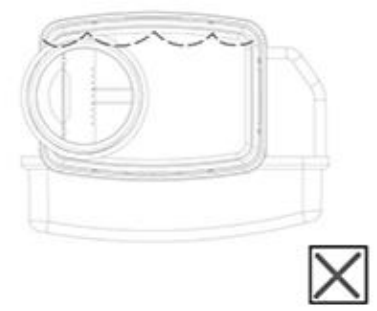
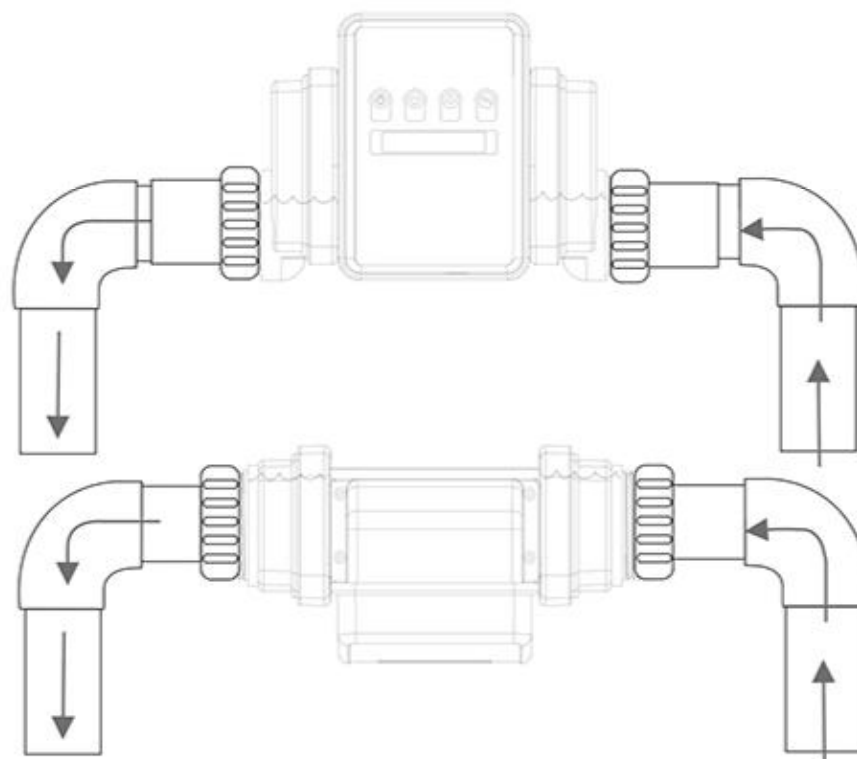
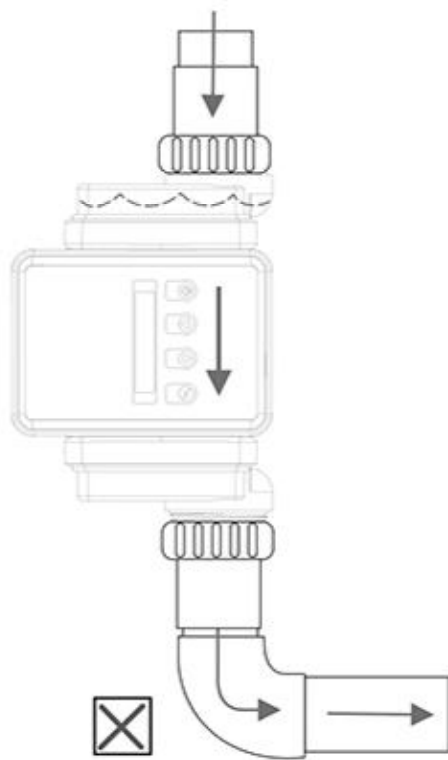

**Caution:** Do not try to use the other cable to replace the Salt Chlorinator cable. If the connection cable is not long enough. Please contact the Local dealer for more information. The cable needs to deliver high current thus special electrical cable is required.

## The 20G Salt Chlorinator System Description

- 1) Install the Electrolysis Cell in the Pumping system and make sure the Filter is 100% clean.  
Copper, iron and algae will damage the electrolysis cell permanently
- 2) Connect the cable between the Power Pack and Filtration Controller / Distribution Box
- 3) Add salt to Swimming pool water (3 to 6 grams per liter, or 3~6 kg/m<sup>3</sup>). You may also calculate the Volume of the pool to know how much salt to add the pool \*\*\*Salt [kg] = Length[m] x Breadth[m] x Average Depth[m] x 3 \*\*\*
- 4) Run the pump and ensures proper water flow. Run the pump for 24 hours during first time setup for proper mixing of salt and water. The swimming pool water must be cycled thru the pump as this will dissolve the salt evenly in the swimming pool. \*\*\*Note: Water level must flow over 90% in the CELL in order for the system to work probably. \*\*\*
- 5) Turn on the SaltCELL Chlorinator.

## 20G Controller System Description

The SaltCELL system is designed to be fool-proof with simple operation.

Cleaning of the electrolysis cell will be done automatically during normal system operation.

Thus, user will only be required to adjust the production rate (level) of the chlorinator to the desired value.



### SUPER SHOCK :

Turn on the 1 hour turbo mode programme. It will create 20g chlorine during 1 hour period. After 1 hour working, it will turn back to the per-set mode.



### LEVEL UP:

Increase the chlorine output level.



### LEVEL DOWN:

Reduce the chlorine output level.



### POWER ON/OFF

Switch On and Off the salt chlorinator.

Once the level is set, no other setting is required by the user, System will operate automatically once it is powered on!

Display Level	Production chlorine rate [g/hour]	Pool size	Gallons water
LEVEL 1	6.0 gr/hr	2 x 4m cube	Below 15000lite
LEVEL 2	8.0 gr/hr	3 x 6m cube	15000-30000liter
LEVEL 3	12.0 gr/hr	4 x 6m cube	30000-45000liter
LEVEL 4	16.0 gr/hr	4 x 8m cube	45000-55000liter
SUPER SHOCK	20.0 gr/hr	Extremely Hot Environment	

## Pool owner useful information

The pH of the pool have to maintained in the range of 7.2-7.6. The effectiveness of the chlorine as a sanitize is significantly reduced as the pH rises. At a pH of 8.0 nearly all of the chlorine being added to the pool is wasted. If the pH readings at 8.0 and higher increase scale formation which may require manual clearing of the cell.

In a New pool ( Where there is no salt residual) of approximately 15,000 gallons, 8 x 50lb of salt are required to reach a 4000ppm concentration. It is recommended that outdoor swimming pools be disinfected with between 2~5mg per litre of chlorine. Above 5mg/liter the chlorine starts to irritate the skin and eyes of the swimmers.

## Preferred Water Chemistry Readings

Salt concentration	4,000ppm
pH	7.2 to 7.8 (Ideal range of 7.4 to 7.6)
Chlorine stabilizer(Cyanuric acid)	30-50ppm ( recommend )
Total hardness	200 to 400ppm
Total alkalinity	80 to 120 ppm
Free chlorine	2 to 4ppm

### 20G Salt Chlorinator Display Message

SYSTEM CHECKING PLS WAIT...	System is performing system check while tuning the electrolysis cell to the desired production level -Wait until the screen shows "Cell On " for normal operation.
LEVEL 1 CELL ON	Normal operation -Producing chlorine and performing electrolysis cell cleaning.
PLS CHECK CABLE CONNECTION	Electrolysis cell is missing - Check and secure all electrical connections - Wait until the screen shows "Cell On" for normal operation.
PLS ADD SALT BELOW 3000PPM	Salt level is low -Check for salt level and add salt required - Wait until the screen shows "Cell On" for normal operation.
PLS CHECK PUMPING SYSTEM	Water level is lower than water flow detector "safety level". - Check for proper orientation of the installed electrolysis cell - Turn on the pumping system - Wait until the screen shows "Cell On" for normal operation.
SYSTEM WARMING SALT OVER 6000PPM	System detect water salt level is over 6000ppm. It will damage the cell. -Please contact your pool agents for more information
CELL CONDITIONING PROCESSING...	System self cleaning and restoring the system to normal operation after 10 min. - Wait until the screen shows "Cell On" for normal operation.
SYSTEM ERROR SHORT CIRCUIT	Chlorinator is experiencing short circuit while delivering power to the electrolysis cell Turn off the chlorinator immediately and unplug the AC power cord - Please contact your pool agents for more information
POWER OFF & RESET SYSTEM	Chlorinator is experiencing error. It may be caused by no water/ no pump / no salt in the pool water over 30min. System will stop the auto-checking function and keep under the sleep mode. - Please ensure the cell is full of running water and reset the system

### How to check the Chlorine level in the pool?

20G Chlorinator should first be turned on for 24 hours. Two water samples should be obtained at two different locations:

Location 1: Water outlet

Location 2: Furthest location away from water outlet

If the Chlorine reading from location 1 has a much stronger Chlorine level than location 2, this verify that the system is working correctly.

It is strongly recommended to operate the chlorinator twice per day, 3 to 6 hours per each operation during morning and night period. Running the chlorinator at this period will minimize the effect of evaporating the Chlorine gas by sunlight. If it is necessary to operate the chlorinator during daytime, stabiliser is recommended to stabilize the Chlorine level in the water. In winter, a single daily cycle of 3 ~ 5 hours is sufficient for normal usage. In extremely hot environment, it may be necessary to super-chlorinate the pool once every 2 to 4 week. Please contact the local dealer for more information.



## How much salt in pounds or (KG) need to be added into the pool?

Use the equations below (measurements are in feet/ gallons/meters/liters) if pool size is unknown.

	Gallons (pool size in feet)	Liters (pool size in meters)
Rectangular	Length x Width x Average Depth x 7.5	Length x Width x Average Depth x 1000
Round	Diameter x Diameter x Average Depth x 6	Diameter x Diameter x Average Depth x 790
Oval	Length x Width x Average Depth x 6.5	Length x Width x Average Depth x 900

The pool need add salt 3 to 6 grams per liter or 11to 22 grams per gallon

Example for the salt need to be added in to the pool at the first time using (Salt concentration 0ppm)

Salt Concentration level	Pool Size	Litres	Gallons	Add Salt level
0ppm	3m x 6m x 1.6m	29000 Liters	7600 Gallons	190lb / 80kg
0ppm	4m x 8m x 1.6m	51000 Liters	13500 Gallons	330lb / 150kg
0ppm	5m x 10m x 1.6m	80000 Liters	20000 Gallons	530lb / 240kg

Example for the salt need to be added in to the pool under the different Salt concentration level.

Salt Concentration level	Pool Size	Litres	Gallons	Add Salt level
1000ppm	3m x 6m x 1.6m	29000 Liters	7600 Gallons	130lb / 60kg
1000ppm	4m x 8m x 1.6m	51000 Liters	13500 Gallons	220lb / 100kg
1000ppm	5m x 10m x 1.6m	80000 Liters	20000 Gallons	330lb / 150kg
2000ppm	3m x 6m x 1.6m	29000 Liters	7600 Gallons	70lb / 30kg
2000ppm	4m x 8m x 1.6m	51000 Liters	13500 Gallons	110lb / 50kg
2000ppm	5m x 10m x 1.6m	80000 Liters	20000 Gallons	150lb / 70kg
3000ppm	3m x 6m x 1.6m	29000 Liters	7600 Gallons	15lb / 8kg
3000ppm	4m x 8m x 1.6m	51000 Liters	13500 Gallons	25lb / 12kg
3000ppm	5m x 10m x 1.6m	80000 Liters	20000 Gallons	30lb / 15kg

### Caution on the Salt level

Add salt as required maintain 3500~4000ppm concentration.

Add 1.25lb (0.6kg) of stabilizer per 50lb (23KG) of salt

The Stabilizer reading should be maintained at 30~50ppm

Low salt concentration level below 2000ppm will cause the Salt Chlorinator to turn off

High salt concentration level over 6000ppm may cause corrosion damage to pool fixtures

### Troubleshooting

Problem	Solution
Green Water, Slippery walls, Green deposition on the wall.	Increase the chlorine level up to 10ppm and pH to 7.2-7.6. Turn on the system for 8 hours per day. Sweep pool walls and floor.
Cloudy or appearance of white or grayish incrustations on wall and accessories	Check filter. Add flocculant and adjust pH to 7.2 -7.6. Sweep pool walls and floor.
Corrosion of accessories appearance of brown spots Eye irritation & hair bleaching	Result from High chlorine concentration or pH lower than 7.0. Reduce the Chlorinator power level or operation time. Adjust pH to 7.2-7.6.
Foams	High levels of organic substances in the water. Empty the water and replace with fresh water. Increase the chlorine level and add flocculent. Adjust pH to 7.2-7.6. Turn on system continuously for 8 hours per day.

### How to maintenance the CELL unit ?

The Electrolysis cell unit has an automatic electrode clearing system that avoids scale deposits on the electrode surface.

The electrodes ***MUST NOT*** be scrubbed manually as that will damage them.

However, after every two months of operation, it is necessary to further clean the electrodes,

Please follow this process (exact following of this process is important):

1. Unscrew the top cover ( Photo 1 ) and Disconnect the power supply
2. Make up a solution of 10(ten) parts water to 1 (one) part pool acid. (HCL) or use straight vinegar.
3. Use a container for cleaning solution that will allow you to submerge only the electrodes.
4. After being submerged in the cleaning solution, rinse off with fresh water. A powerfull water stream is best for this but do not use extreme pressure like from pressure washer. This will cause permanent damage.
5. ***DO NOT*** scrape or brush the electrodes as that could permanently damage the plates.

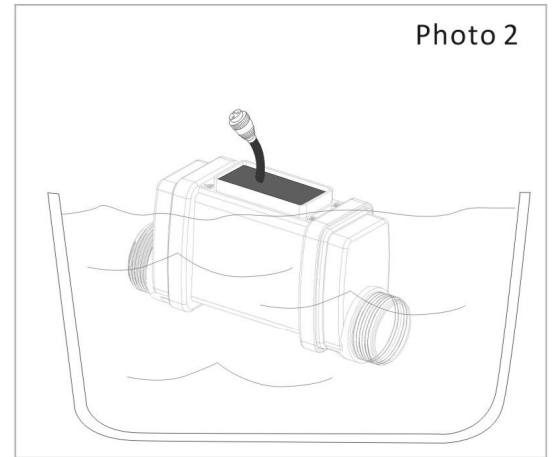
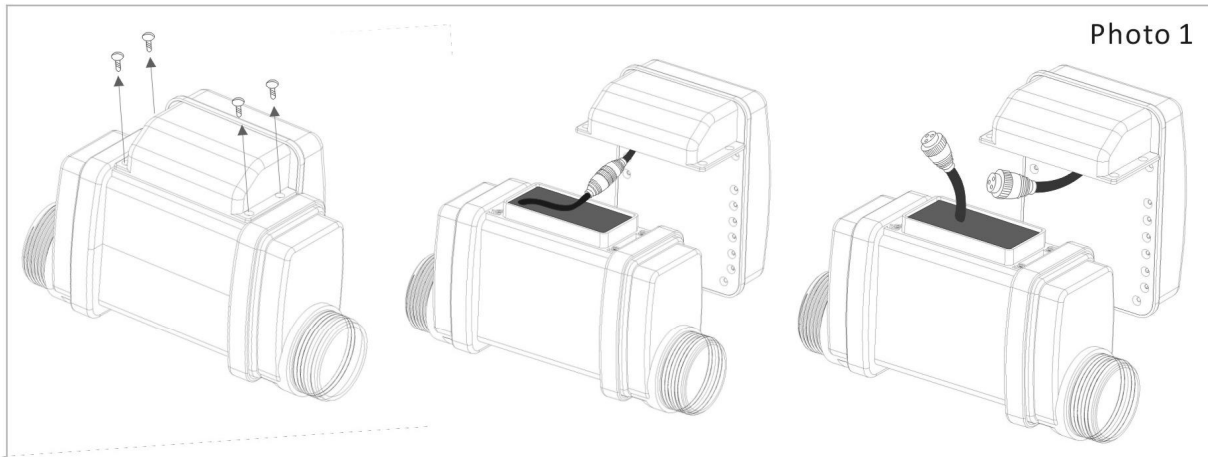

### Warranty

AquaIDEA warrants that 20G Salt Chlorinator is free from any defects in materials and workmanship for a period of 1 year from the date of purchase. This warranty shall not apply to defects caused by abnormal using of , or incorrect application of, or incorrect installation of the above mentioned equipment, or by neglect on the part of any person other than AquaIDEA.

This warranty shall lapse if any repairs are attempted or affected by any person not authorized thereto by AquaIDEA.

Consequential damages or costs however arising are expressly excluded.

In order to inquire about warranty claims, please contact your local dealer or email to : [contact@aqua-idea.com](mailto:contact@aqua-idea.com)

### Remark

---

---

---

---

---

---

---

---

---

---

### Pool agent contact information:

---

---

---